

LTR	ZONE	REVISION	DATE	ECN	DRN
-	-	-	-	-	-

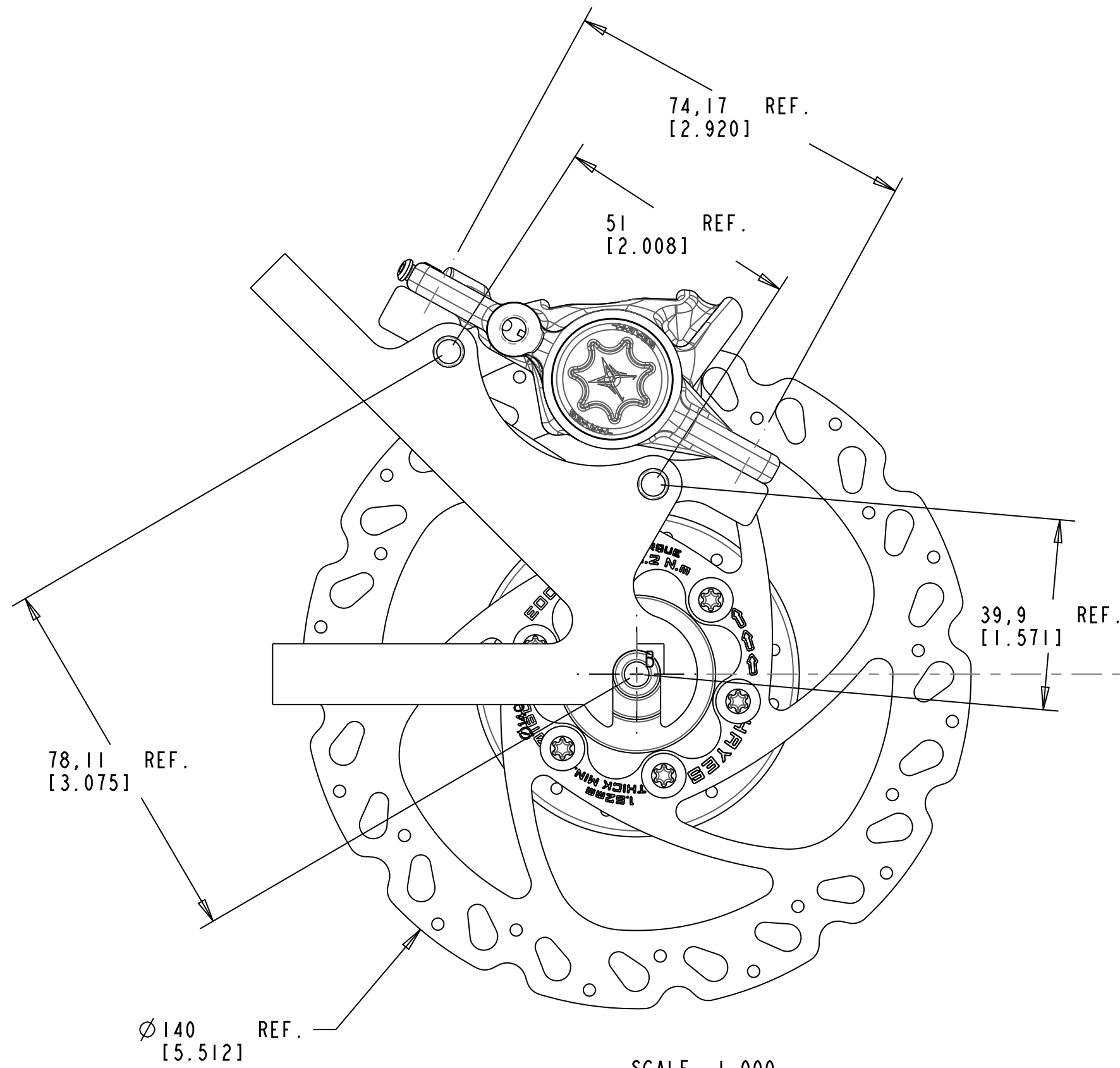

SCALE 1.000

CENTER OF DROPOUTS

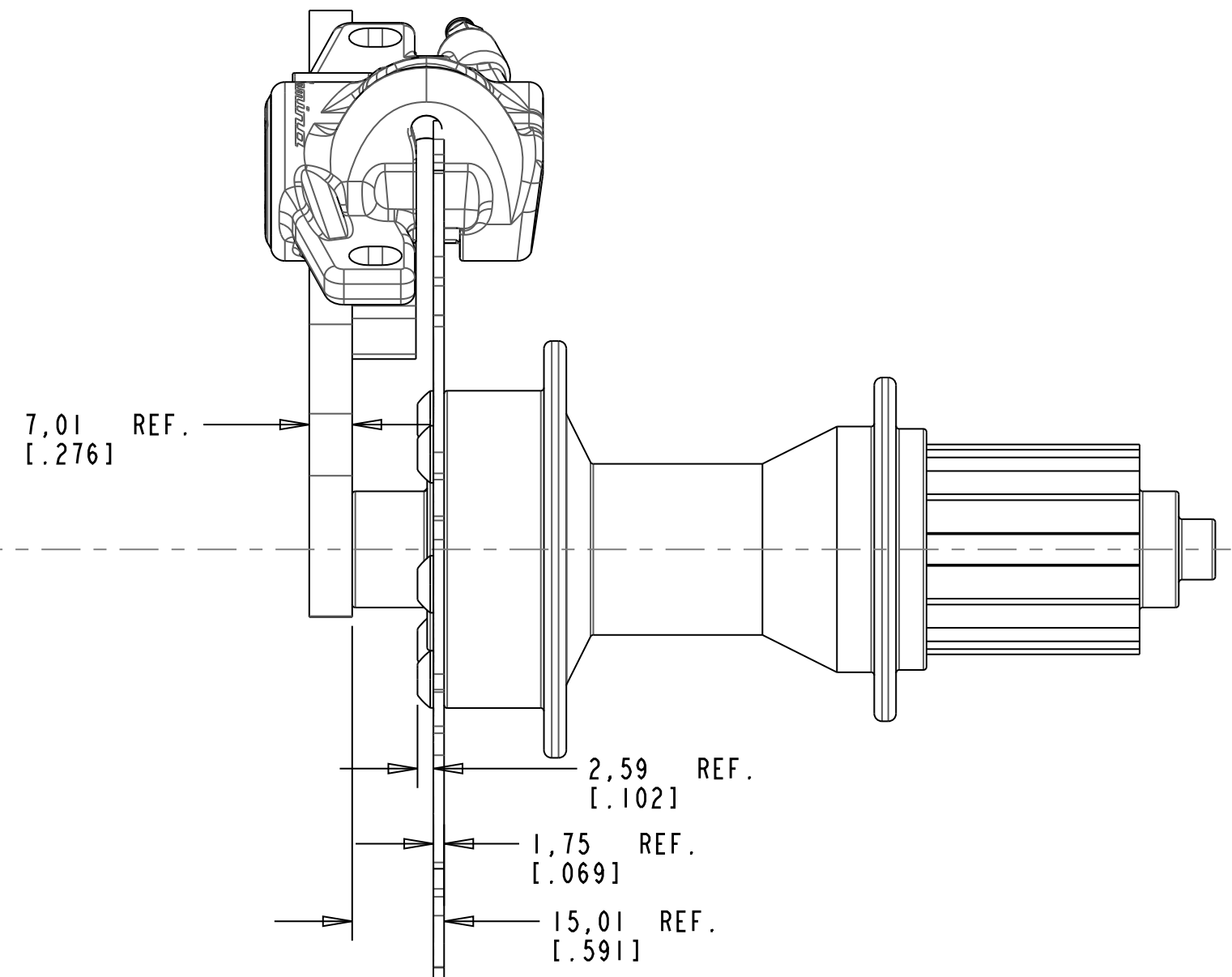

UNLESS OTHERWISE SPECIFIED:  
BREAK ALL CORNERS & REMOVE ALL BURRS .137/.38 [1.0057/.015] RADIUS OR CHAMFER. MACHINED SURFACE FINISH TO BE 3.2 [126].

PRO-ENGINEER	SPEC No.
TRACEABILITY	
CHARACTER CLASSIFICATION	
CRITICAL	
MAJOR	
MINOR	45-009
INCIDENTAL	89-008

SPECIFICATIONS	
CLASSIFICATIONS OF CHARACTERISTICS	
CLEANLINESS REQUIREMENTS	

Section 4.1.7 Residual Magnetism	X
Section 4.1.6 Smut	X
Section 4.1.5 Water	X
Section 4.1.4 White Corrosion	X
Section 4.1.3 Red Rust	X
Section 4.1.2 Oils & Greases	X
Section 4.1.1 Chips, Dirt, Dust, Cardboard & other Foreign Matl.	X
CATEGORY	CLASS
SPEC 89-008	

**HB PERFORMANCE BICYCLE GROUP**

ASSEMBLY, REAR IS,  
140 MM DISC

DWG NO.	96-22101	REV	1
REL LEVEL	Prototype	SHEET	1 OF 1

4

3

2

1

D

D

C

C

B

B

A

A

4

3

2

1