

LTR	ZONE	REVISION	DATE	ECN	DRN
I	-	DRAWING CREATED	12/23/08	-	GM

D
C
B
A

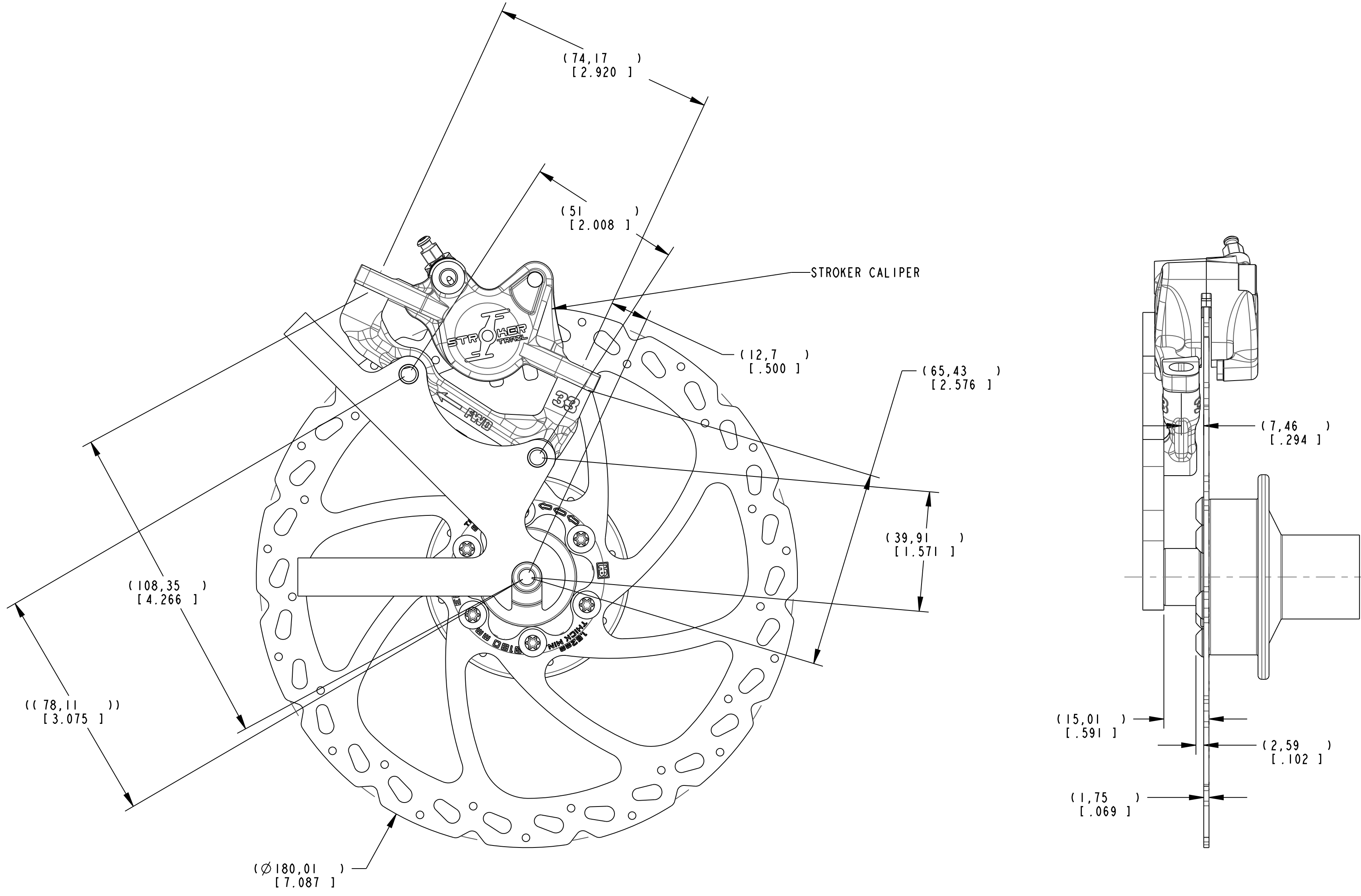

UNLESS OTHERWISE SPECIFIED: BREAK ALL CORNERS & REMOVE ALL BURRS .137/.38 [.0057/.015] RADIUS OR CHAMFER. MACHINED SURFACE FINISH TO BE 3.2 [.126].	PRO-ENGINEER	SPEC No.	SPECIFICATIONS
	(T) TRACEABILITY		
	CHARACTER CLASSIFICATION		
	(●) CRITICAL		
	(●) MAJOR		
(○) MINOR	45-009	CLASSIFICATIONS OF CHARACTERISTICS	
(○) INCIDENTAL	89-008	CLEANLINESS REQUIREMENTS	

Section 4.1.7 Residual Magnetism	X	All of the information shown herein is the exclusive property of HB Performance Systems Inc. and is submitted only on a confidential basis. The recipient agrees that no disclosure of this information will be made to a third party without written consent of HB Performance Systems Inc.
Section 4.1.6 Smut	X	
Section 4.1.5 Water	X	
Section 4.1.4 White Corrosion	X	
Section 4.1.3 Red Rust	X	
Section 4.1.2 Oils & Greases	X	
Section 4.1.1 Chips, Dirt, Dust, Cardboard & other Foreign Mat.	X	
CATEGORY	CLASS	
SPEC 89-008		

HB PERFORMANCE BICYCLE GROUP

**REAR INSTALLATION
I.S., 180mm DISC, STROKER**

DWG NO.	98-24962	REV	I
DRN	GM	DATE	12/23/08
SCALE	1.000	SIZE	C
REL LEVEL	ECN	SHEET	I OF I

4 3 2 1

4 3 2 1